



TEXAS INSTRUMENTS
INCORPORATED

SR-52 AND SR-52A
TROUBLESHOOTING GUIDE

SR-52 AND SR-52A
TROUBLESHOOTING GUIDE

by

Jim Johnson
Kevin Hines
Donna Davis

Don Young

Section 1

GENERAL DESCRIPTION

PURPOSE

The purpose of this manual is to describe the operational theory of the SR-52 and SR-52A and to give guidance in its repair.

Section 2

SR-52 and SR-52A THEORY OF OPERATION

GENERAL

The SR-52 and SR-52A electrically can be broken into nine individual sections. They are:

1. Power Supply
2. Clock
3. MOS
4. Keyboard
5. Display Interface
6. Motor Control
7. Card Sensor Input
8. Magnetic Read/Write Mechanism

A block diagram of the SR-52 and SR-52A show the relationship between the individual sections. A discussion on the theory of operation will be given on the circuit analysis of each of the nine sections.

APPENDIX

1. Board Layout SR-52 Rev. A through C Board
2. Board Layout SR-52 Rev. D through J
3. Board Layout SR-52 Rev. L
4. Board Layout SR-52A
5. Schematic SR-52 Rev. D through L
6. Schematic SR-52A
7. Waveforms SR-52 and SR-52A
8. Repair Parts List SR-52
9. Repair Parts List SR-52A

SR-52 POWER SUPPLY

The SR-52 uses a switching regulator power supply to convert the battery voltage (-3.3 to 4.2 VDC) to the necessary operating voltages of the calculator (-10 VDC and -16 Volts). The batteries are charged by an AC charging circuit. The charging circuit consists of CR5, 6, 7, and 8 which forms a full wave bridge rectifier. R1 limits the charge current through the batteries when the calculator is turned off to approximately 150 mA.

The switching regulator portion of the power supply consists of a free running oscillator, and output rectifier and filter, voltage doubler and a regulator circuit.

The free running oscillator is made up of R1, R4, C1, CR9, CR12, T1, Q1, and Q2. When power is applied to the circuit, Q1 is turned off and Q2 is in saturation. The current flowing through T1 increases until it is limited by Q2. When the current through T1 ceases to increase, the voltage across T1 reverses, saturating Q1, (C1 acts as a short circuit when the voltage on T1 reverses) and turns Q2 off. When the stored energy in T1 is expended, Q1 turns off and Q2 is again saturated, and the process starts over. Note that when CR12 is reversed biased, it acts as a capacitor for faster turn on of Q1 and CR9 protects the base emitter junction of Q1 from reverse voltage spikes.

The output rectifier CR19 converts the stored energy from T1 to DC voltage which is then filtered by C2 to create Vdd. The voltage doubler (C3, C4, CR14, and CR15) adds to Vdd to create Vgg.

The regulator circuit consists of CR10 and CR11 and R2. When the output voltage, Vdd exceeds the combined forward bias voltages of CR10 and CR11, current flows through the base of Q1 turning it on (The base current is limited by R2). Therefore, the circuit is voltage regulated.

Vss	0 Volts	0 Volts	-Vbatt	-4.3	- -3.3
Vgg	-16.3	-15.3	Vdd	-10.5	- -9.5

SR-52A POWER SUPPLY

The SR-52A uses a power supply module to convert the battery voltage (-3.3 to -4.2 VDC) to the necessary operating voltages of the calculator (-10 volts and -16 volts). The batteries are charged by an AC charger and charging circuit.

CHARGING CIRCUIT

The charging circuit consists of CR5, 6, 7, & 8, BP-1 and R1. The full wave bridge (CR5, 6, 7, & 8) converts the AC voltage supplied by the AC charger (AC9130A) to DC. Resistor R1 limits the charge current through the batteries (BP-1) when the calculator is turned off to approximately 150 mA.

POWER SUPPLY PARAMETERS

PARAMETER	MIN (Volts)	NOM (Volts)	MAX (Volts)
VSS	-	0	-
V-Bat	-4.3	-3.75	-3.3
VDD	-10.5	-10.0	-9.5
VGG	-15.3	-15.8	-15.3

SR-52 CLOCK GENERATOR

A two phase clock, necessary to drive the SR52 logic, is generated by U10. U10 is a bipolar integrated circuit to produce the two phase clock. The ceramic resonator Z1 resonates at a frequency of 384 KHz $\pm 1\%$, which establishes a stable frequency source for the clock circuit. U10 divides the 384 KHz by two to produce a 192 KHz $\pm 1\%$ two phase clock with a 20% downtime. R5, R6, C5, and C6 condition the wave form from Z, to produce the proper clock downtime. R16 and C7 filter VBatt to isolate U10 from power supply noise, and R21 prevents U10 from locking up during the power sequence. U11 conditions the clock signals to properly drive the MOS chips.

SR-52A CLOCK GENERATOR

The two phase clock necessary to drive the SR-52A logic is generated by the 534. The ceramic resonator, Z1, resonates at a frequency of 384 KHz \pm 1% which establishes a stable frequency source for the clock circuit. The 534 divides the 384 KHz by two to produce a 192 KHz \pm 1% two phase clock with a 20% downtime. U10 (TP0190) conditions the clock signals to properly drive the MOS chips.

SR-52A MOS

The MOS chip set consists of seven MOS devices. They are:

- 1) ARITHMETIC LOGIC CHIP (TMC501)
- 2) SCOM (TMC0534) - Scanning Read Only Memory
- 3) Two BROM's (TMC0562 & TMC0563) - Bare Read Only Memories
- 4) Two MULTI-REGISTER CHIPS (TMC0599)
- 5) MAG. I/O CHIP (TMC0595)

1) ARITHMETIC LOGIC CHIP (TMC0501E)

The arithmetic logic chip, U1, performs the required mathematical operations using instructions from the SCOM and BROM's. The I/O, IRG, IDLE, and EXT lines are the communication links between the drivers. The arithmetic logic chip also receives instructions from the keyboard on its K lines and drives the display segments with the S (A-H) and DPT lines.

2) SCOM (TMC0534)

The SCOM (U2) consists of a 13K word ROM used to store necessary functions used by the arithmetic logic chip. The SCOM also creates the display digit select signals (D-lines) and contains a special ROM which stores constants used in logarithmic and trigonometric functions. In addition to the above, the 534 also generates the 2 phase clock pulses that are necessary to drive the MOS chips.

3) BROMs (TMC0562, 0563)

Each BROM (U3 & U4) provides a ROM extension of 1024 words for the SCOM, and uses the IRG, IDLE, and EXT lines to communicate with the SCOM and arithmetic logic chip. They also control motor turn on and turn off & also the power up clear.

4) MULTI-REGISTER CHIP (TMC0599)

The multi-register chips (U5 & U6) provide program storage and user memory storage. Each chip has 30 storage registers capable of storing 1920 bits of data.

5) MAG I/O CHIP (TMC0595)

The Mag I/O chip (U7) provides the interface between the four track magnetic card read/write mechanism and the arithmetic logic chip. Communications between the Mag I/O chip and arithmetic logic are carried on the IDLE, EXT, and IRG signal lines. The Mag I/O chip also conditions the signals to and from the magnetic card read/write mechanisms (e.g., motor, CSI, lamp, & CH1-4) to make them compatible with MOS logic levels.

KEYBOARD

The keyboard is a simple switch matrix which connects a D-line signal from the SCOM chip to a K-Line input on the arithmetic logic chip when a key is pressed. Figure 2.4 shows the keyboard matrix with the approximate D and K-line connections for each valid instruction.

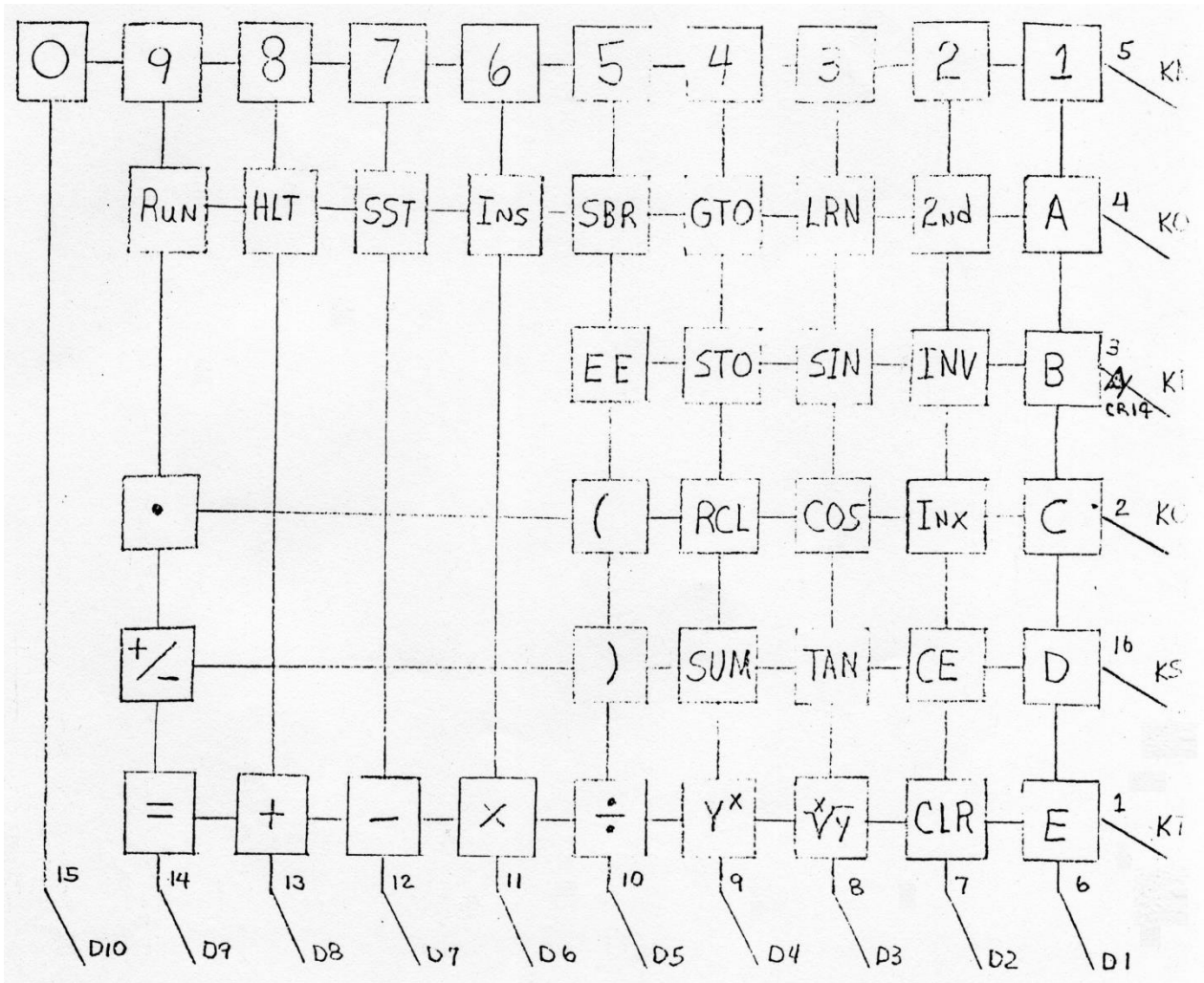

DISPLAY INTERFACE CIRCUIT

The display is a fourteen digit, common cathode seven segment display. Each digit is driven by a D-line signal buffered by U8 or U9, and the segments are driven by the arithmetic logic chip such that the appropriate segments are turned on during each digit time.

DISPLAY 1500869

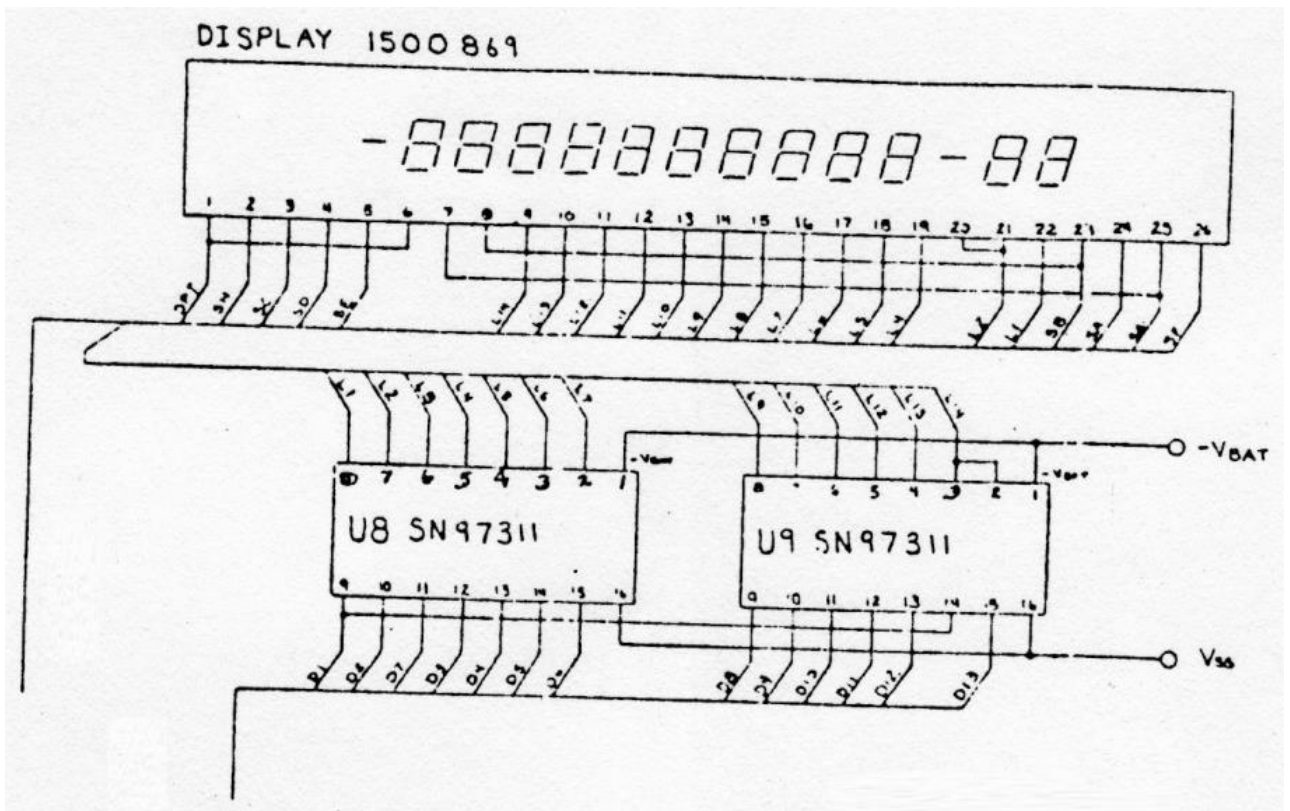

MOTOR DRIVE CIRCUIT

The motor drive circuit is a constant voltage circuit capable of driving the magnetic program card at a constant speed across the magnetic head (3.8 IPS nominal). When the calculator is instructed to read or write (keyboard entry) and the program card is slipped into the read/write mechanism, the card sense switch is opened and contact is broken between D-10 and U1 pin 10. When this occurs U7 pin 9 which is normally at VDD, switches to VSS. Resistors R7 and R9 constitutes a voltage divider which sets up the motor voltage.

- 1) As the value of R2 increases, the base of Q1 becomes more negative. Since Q1 is a PNP transistor, if the base of Q1 becomes more negative the collector becomes more positive.
- 2) If the base of Q2 becomes more positive, Q2 turns on harder trying to reach -VBatt. Result: Motor speed increases.
- 3) As the value of R2 decreases, the base of Q1 becomes more positive, the collector of Q1 becomes more negative. Since Q2 is a PNP transistor, Q2 is trying to turn off or trying to reach VSS. Result: Motor speed decreases.
- 4) As you increase R2, Q1 turns on, turning Q2 on, increasing motor speed. As you decrease R2, Q1 turns off, turning Q2 off, decreasing motor speed.

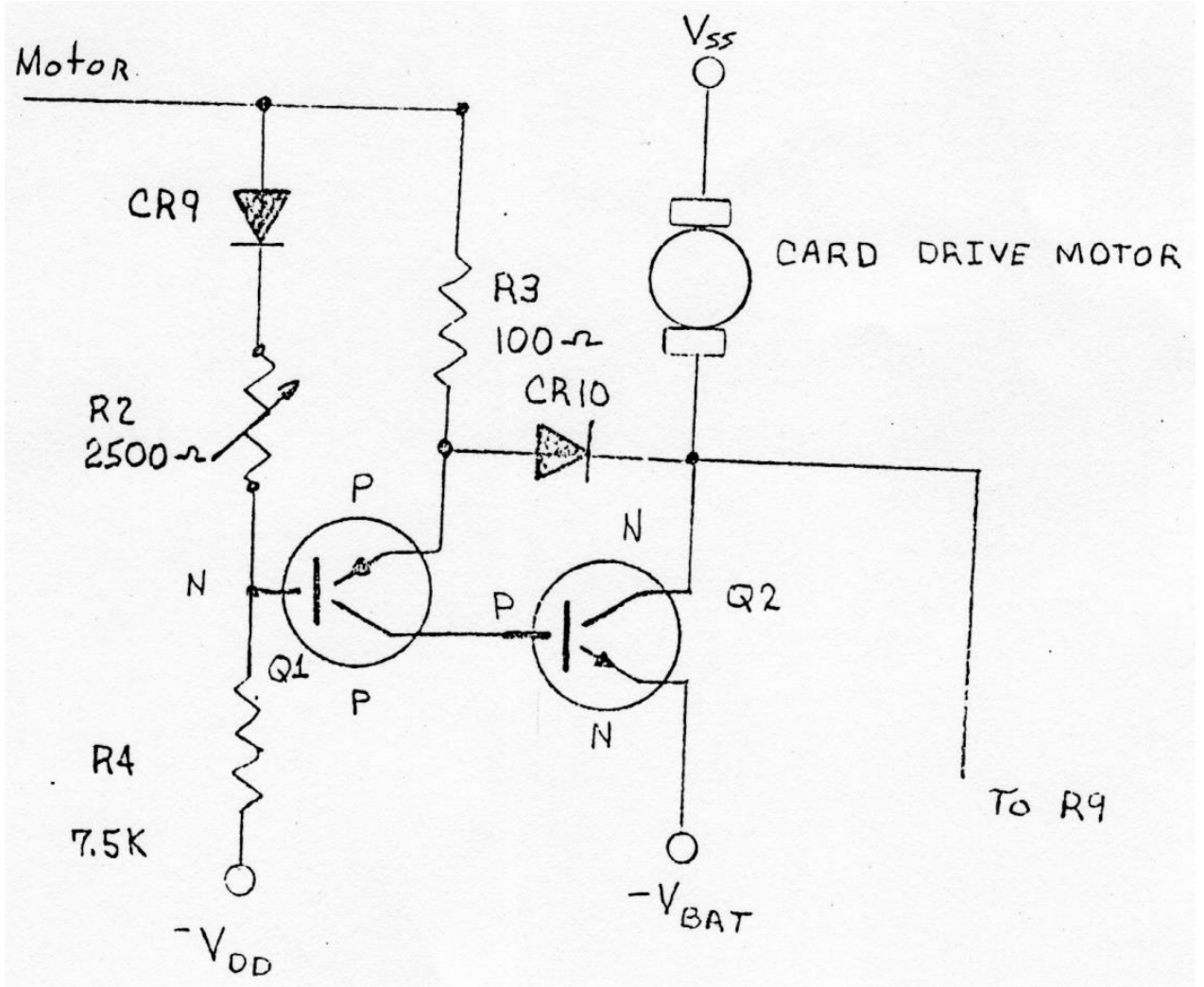

Motor Drive Circuit

CARD SENSOR INPUT SENSOR

The card sensor input (CSI) circuit's purpose is to instruct the mag I/O interface chip (U7) that the program card is under the magnetic head (A1) and in the case of writing a program, that the correct card is being programmed (file protect). Under normal calculator operating conditions the motor is turned off and therefore, no current flows through the light emitting diode (LED) portion of SDA1 and no light is emitted. With no current flowing through the sensor transistor of the SDA1, Q3 is turned on and U7 (pin 10) is held at VDD.

When the calculator is instructed to read or write (keyboard entry) and the program card is slid into the calculator the motor turns on and current flows through the LED - R9 limits the current through the LED. Since the sensor uses reflected light, the current through the sensor transistor is still approximately zero (less than $1\mu\text{A}$) until the leading edge of the program card passes under the sensor. When the program card is under the sensor the sensor transistor conducts current which turns off Q3, drawing U7 pin 10 to VSS. Because of sensitivity variations from one sensor to another, R5 is required to properly bias Q3 allowing the circuit to discriminate between a reflective portion of the program card and a non-reflective portion. R7 & the sensor transistor set up a variable current divider supplied by the current flowing through R5 to allow the necessary guard band between Q3 in saturation and in cut off. CR11 biases Q3 by limiting the base current to no more than $2.5\mu\text{A}$.

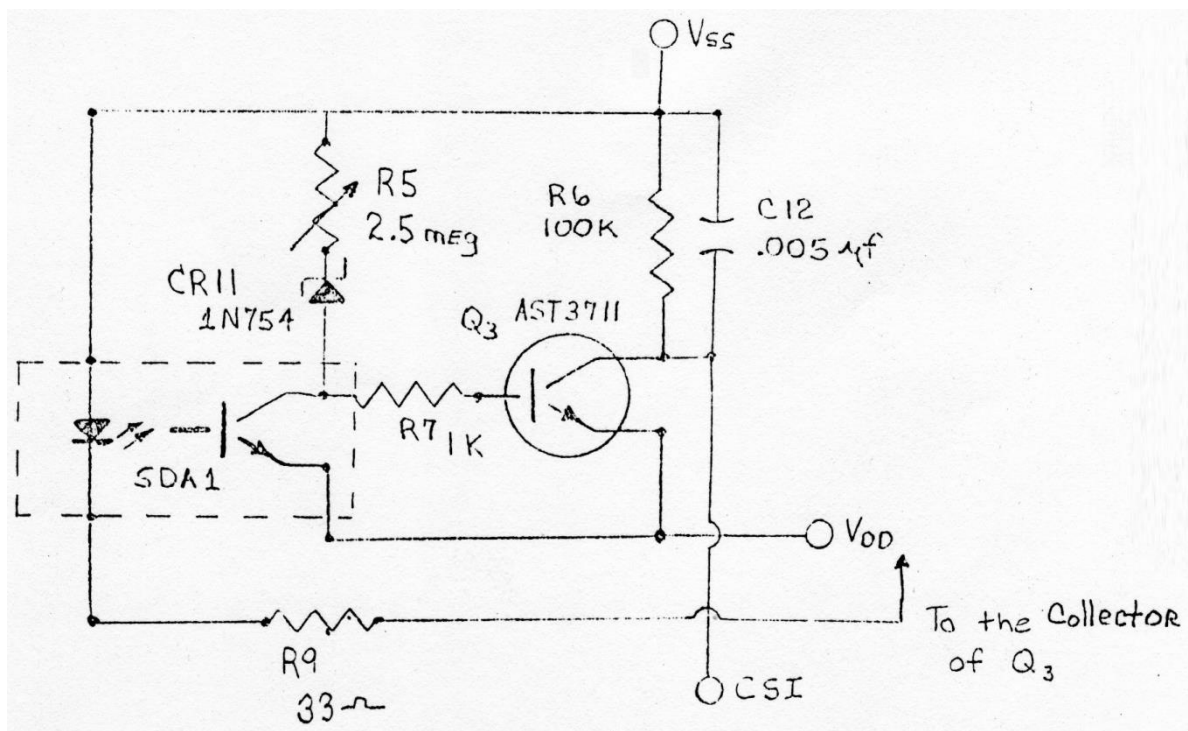

MAGNETIC READ/WRITE MECHANISM

Information transfer between the calculator and the program card is accomplished by the magnetic read/write mechanism. The mechanism consists of a four track magnetic tape head, a normally closed switch and a card drive mechanism.

The magnetic head is driven by four three-state buffers on U7 which allows the MOS to both read and write a magnetic card. The output of the magnetic head (each track) when reading is a series of pulses with alternating polarity approximately six to eight mV peak. The write signal out of the MOS is a square wave switching between approximately VSS and VDD. In both the read and write case, the frequency of the pulses/square wave varies depending upon the particular program (to include no signal on one or two tracks). The magnetic head is oriented such that track one is closest to the edge of the card. The magnetic read/write mechanism has a pressure pad which maintains contact between the magnetic head and the program card. Because the magnetic surface of the card must be in contact with the head throughout reading and writing, it is imperative that the pressure pad is functioning properly.

The card speed is set at 3.8 inches per second (IPS). The calculator will function at a card speed of 3.3 IPS to 4.3 IPS. At any speed below 3.3 IPS, the magnetic head can generate the required output voltage to drive the TMS0595. At any speed above 4.3 IPS, the write length exceeds the length of the card. (It should be noted that the card speed increases during use.) A set up procedure for the card speed is given on the following page.

- 1) Set motor voltage to voltage written on magnetic head.
- 2) Write on a blank card with all zeros (erase card first).
- 3) Spray card with magnetic tape track developer (mag view).
- 4) Measure recording length - it should be between 1.80 to 2.20 inches.
- 5) If out of this range, adjust R7 and repeat steps 2), 3), & 4).
- 6) When speed is within specification, correct voltage written on the magnetic head to read the set voltage.
- 7) Install bottom case and repeat steps 2), 3), & 4). If out of specification return to step 1) and start over.

REFERENCE CIRCUIT

In the TMC0595 I/O chip, to read and write properly, the voltage U7 pin 18 must be maintained within a tight tolerance. This is done by using a reference circuit to set up the threshold voltage for the sense amps in the 595.

When the voltage at U7 pin 11 is at Vdd, Q5 is biased off and the voltage at U7 pin 18 floats at approximately the Zener voltage to maintain a small charge on the feedback capacitors. (C9, C10, C11, C12) When the motor is turned on, the voltage at U7 pin 11 switches from Vdd to Vss. Q5 saturates, and 20 mA flows through the Zener (CR17), setting up the proper reference voltage at U7 pin 18. The reference voltage, and therefore the Zener value, depend upon the 595 revision.

Revision	VRef	Zener	R13*
TMC0595-B	5.1 ± 5%	1N751A	240
TMC0595-C	3.3 ± 5%	1N756A	330
TMC0595-D	-Vbatt	Remove CR17, Q5, R13, R15, R19, and short -VB to -Vbatt	

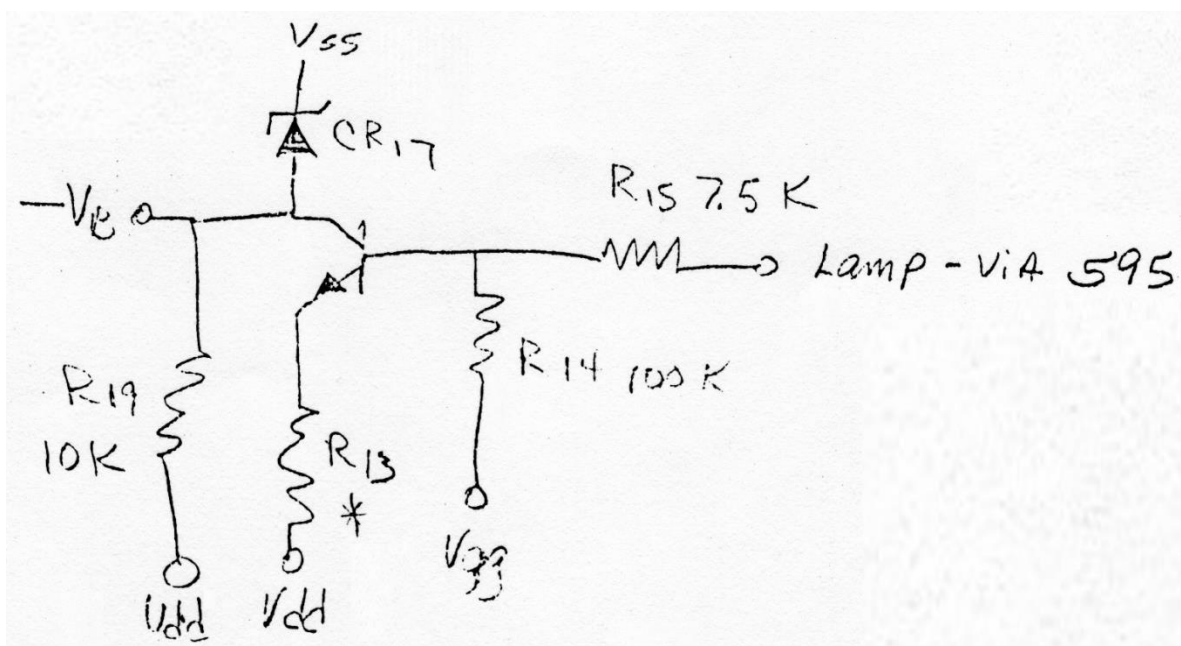

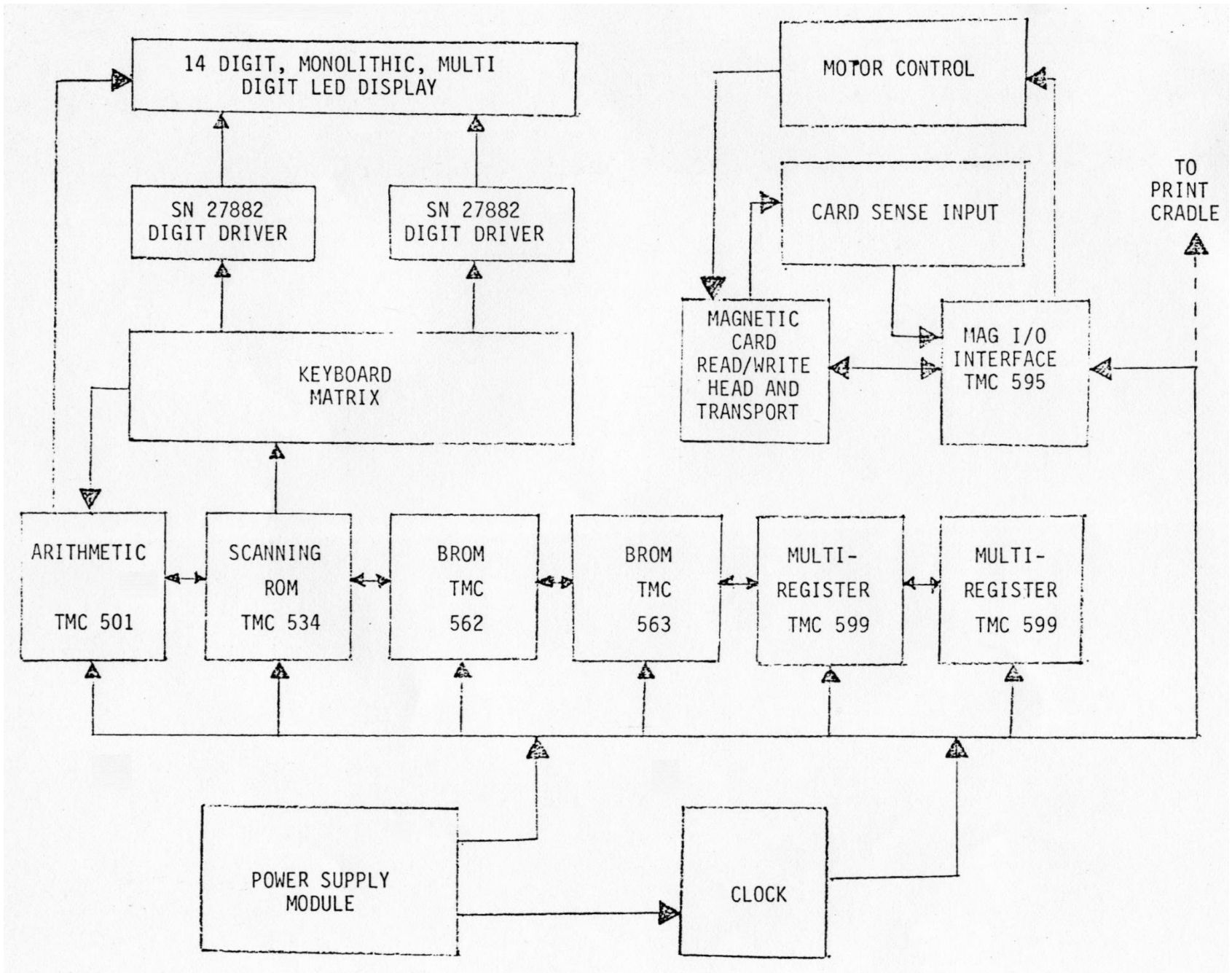

SR-52A BLOCK DIAGRAM

SR-52 WAVEFORMS

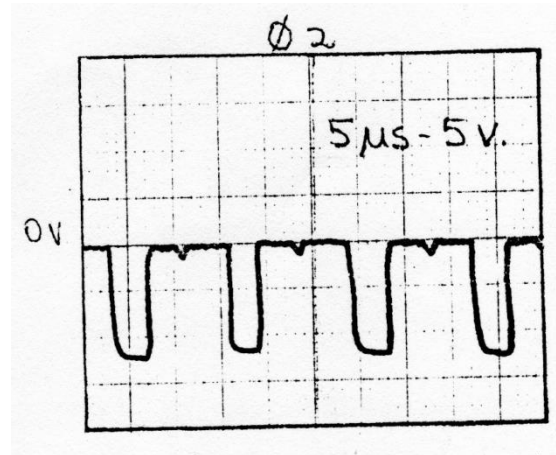
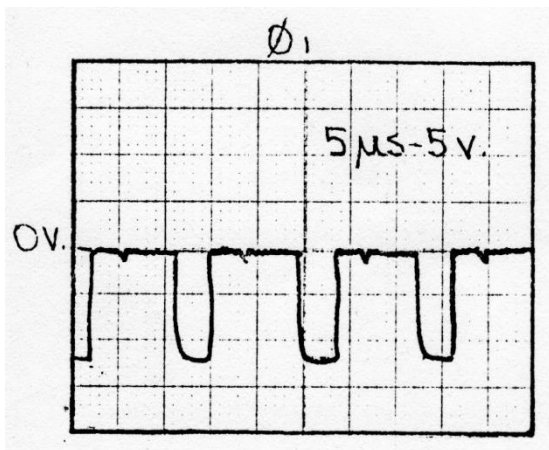
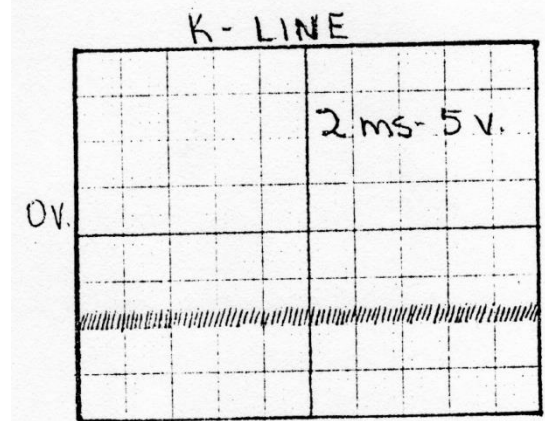
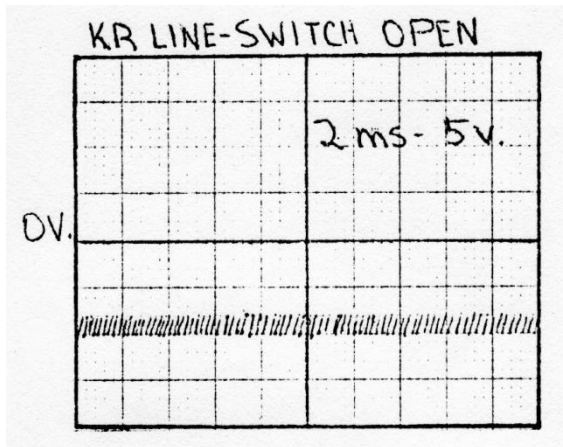
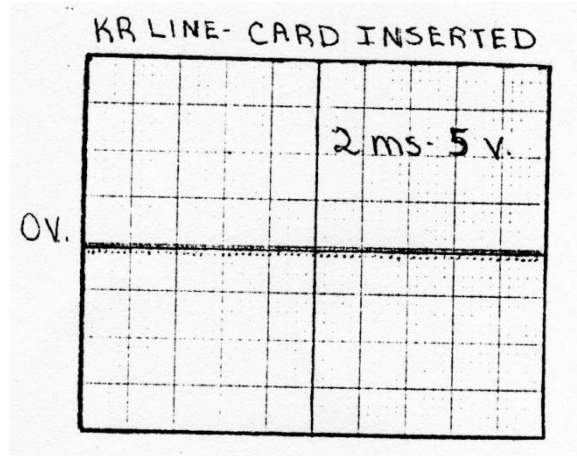
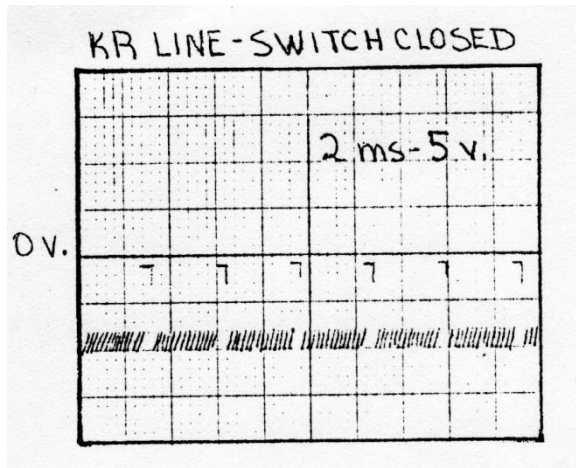

SR-52 WAVEFORMS

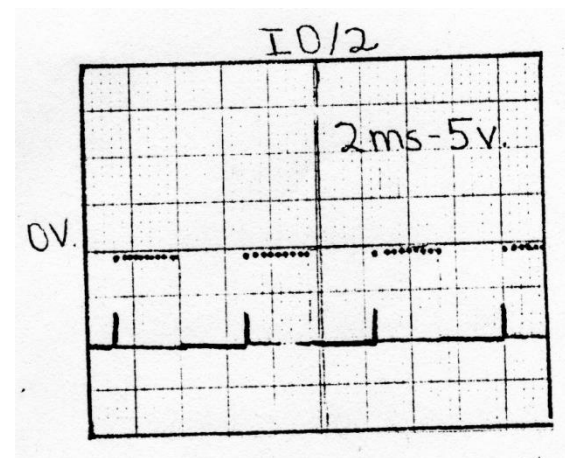
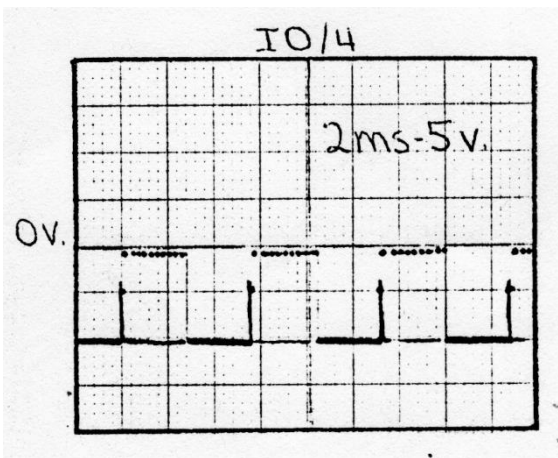
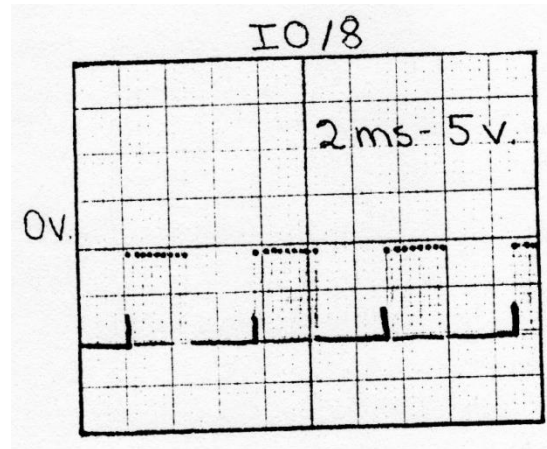
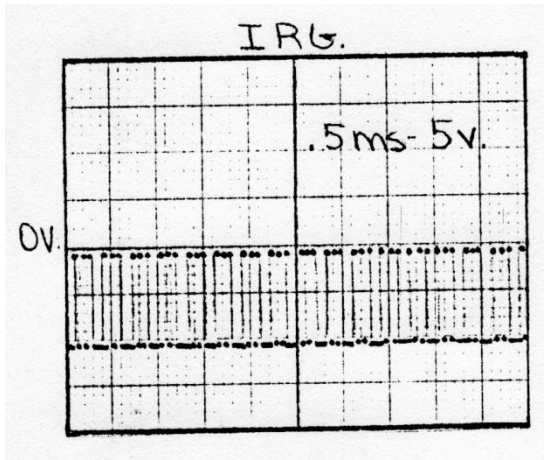
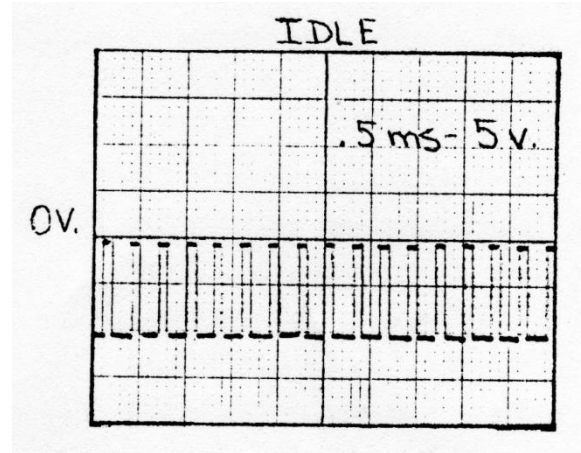
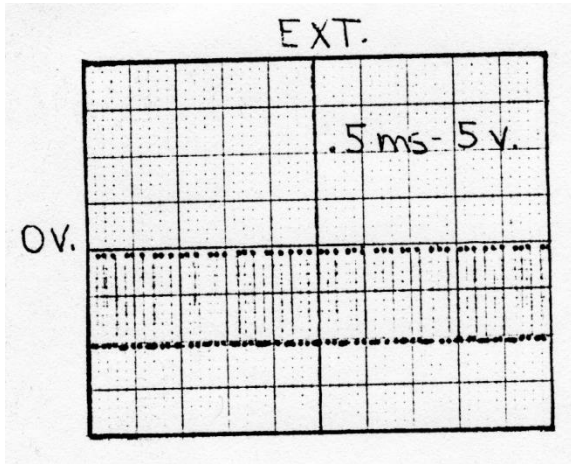

DJD

SR-52 WAVEFORMS

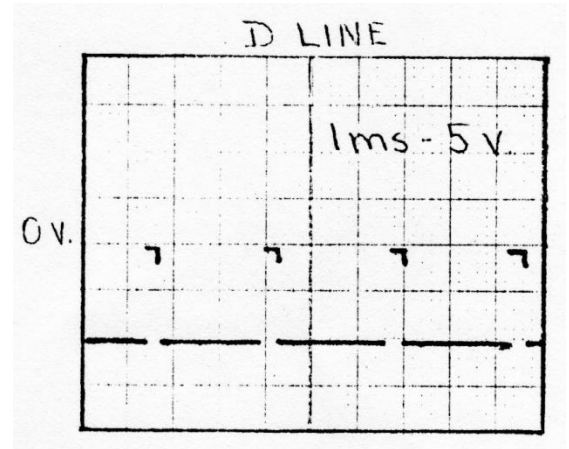
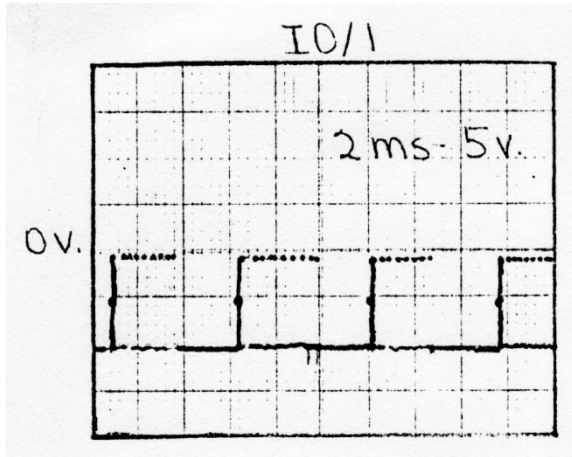

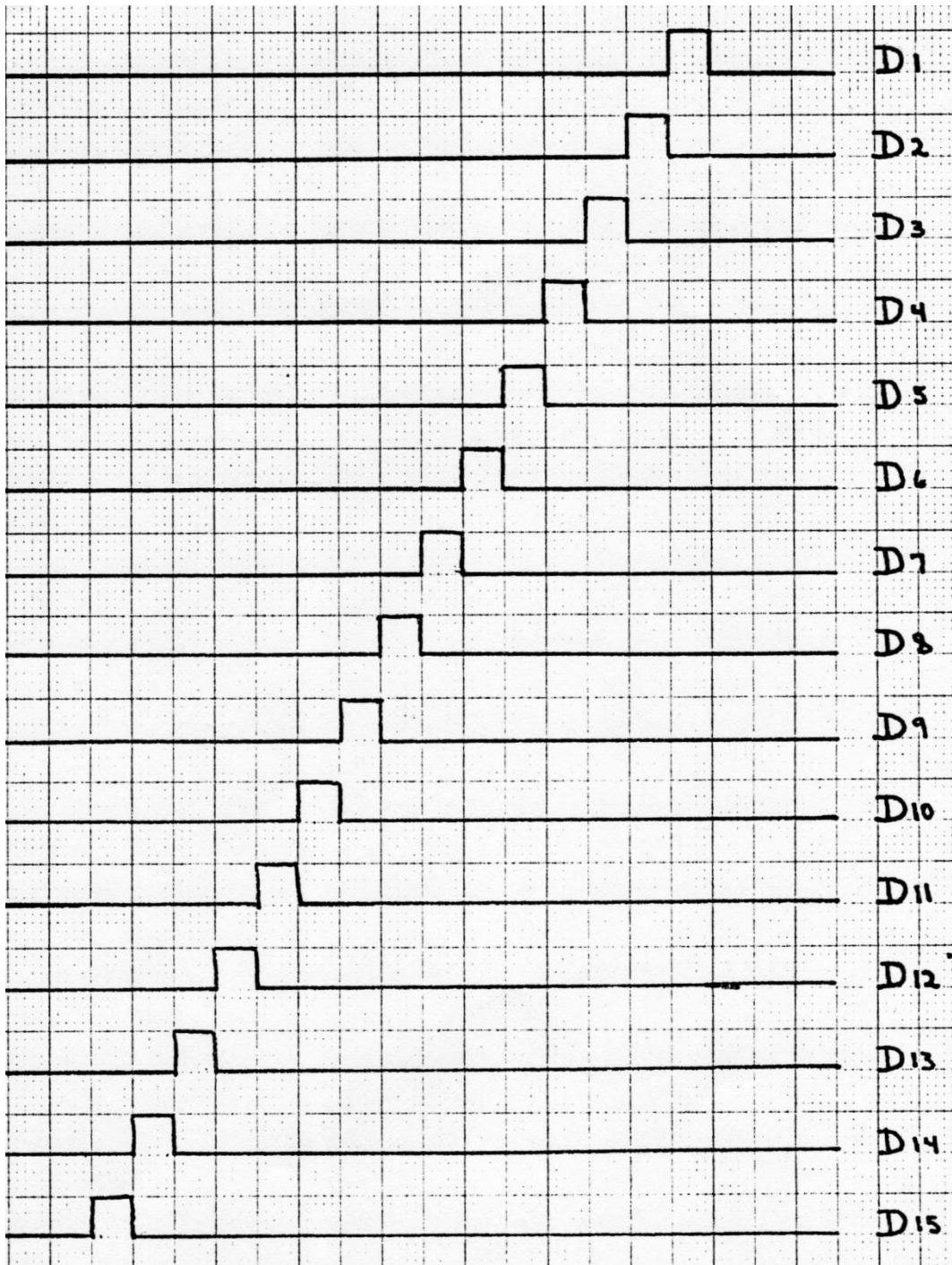

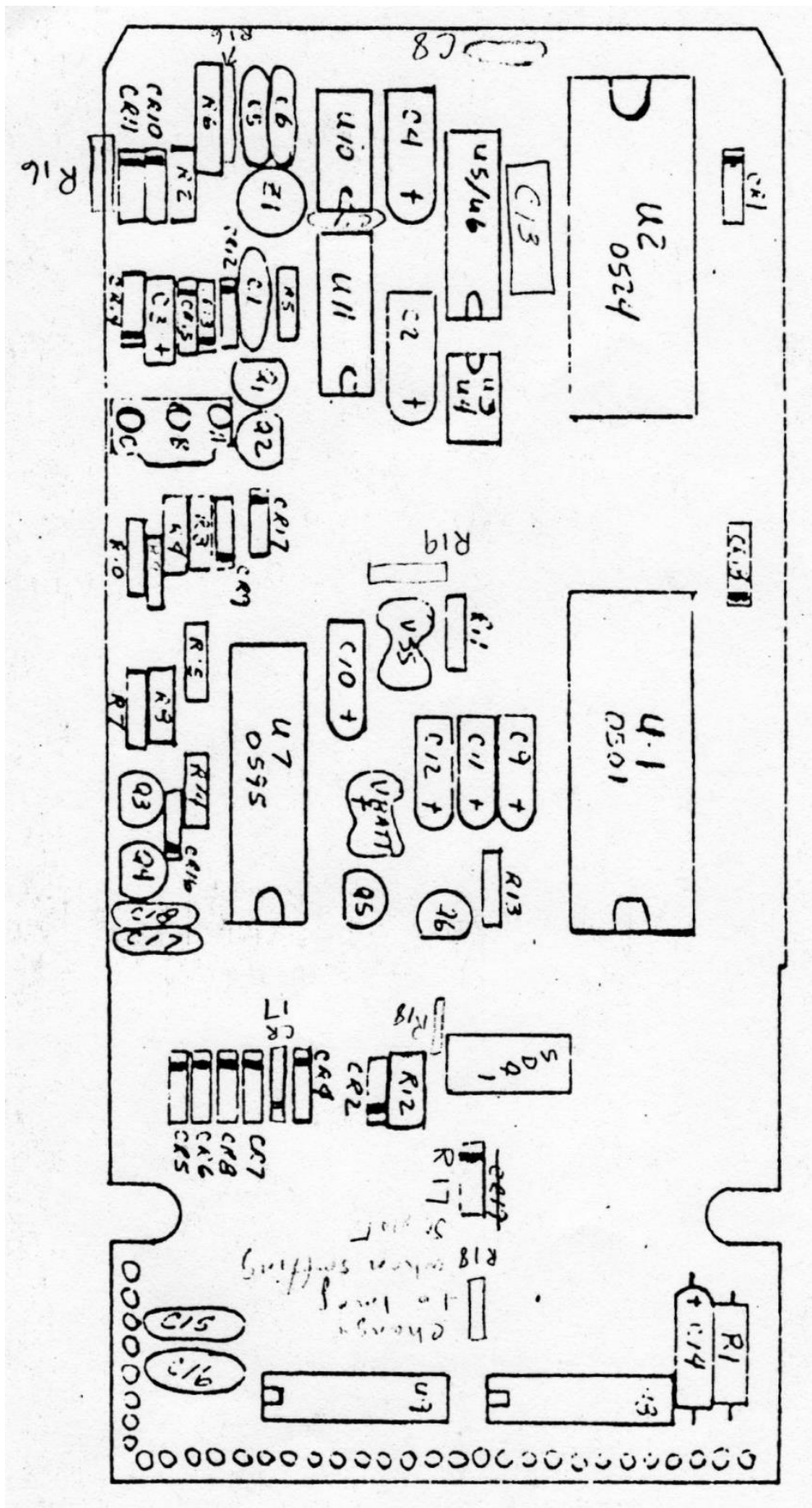

SR-52 Rev. A through C - COMPONENT LAYOUT

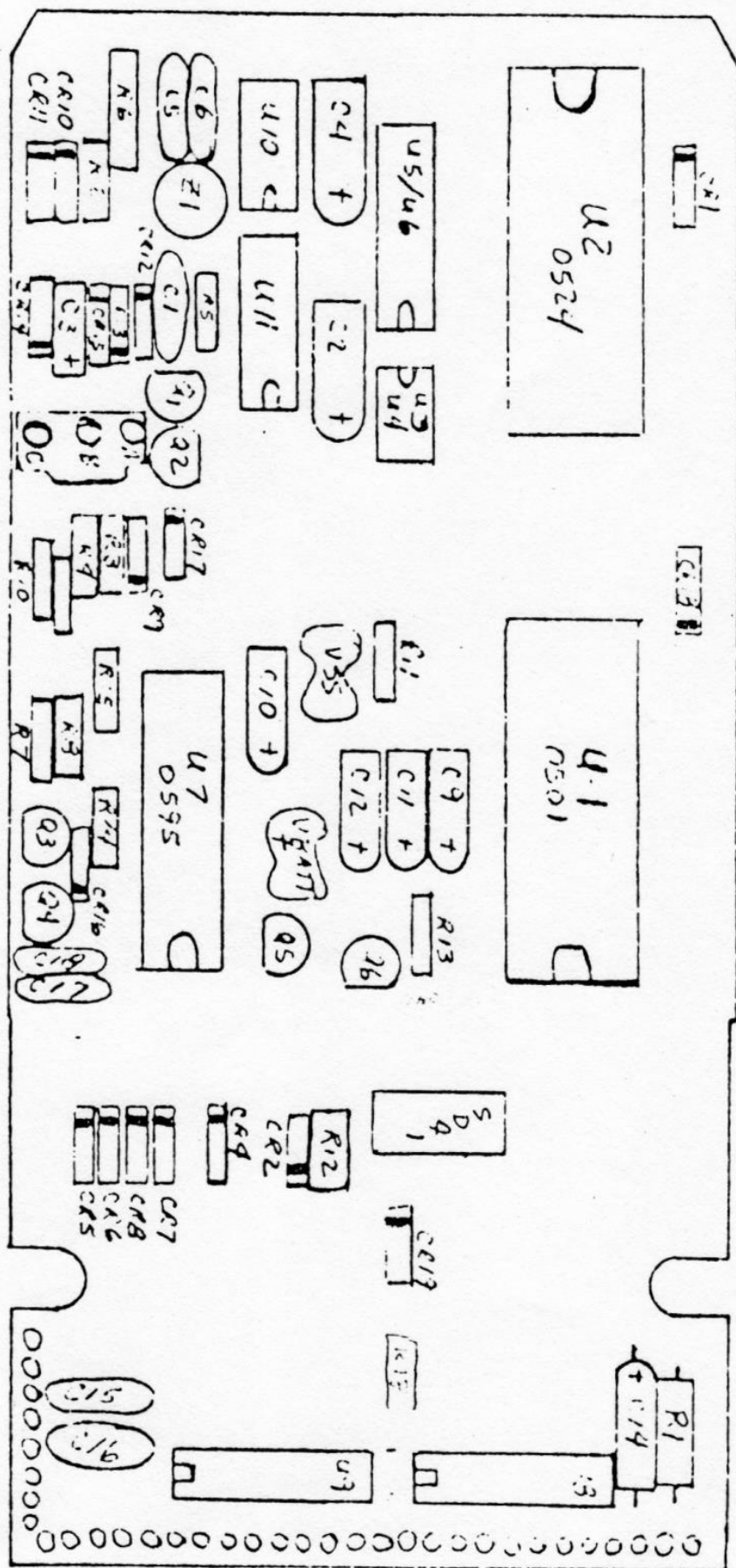

SR-52 Rev. D through J - COMPONENT LAYOUT

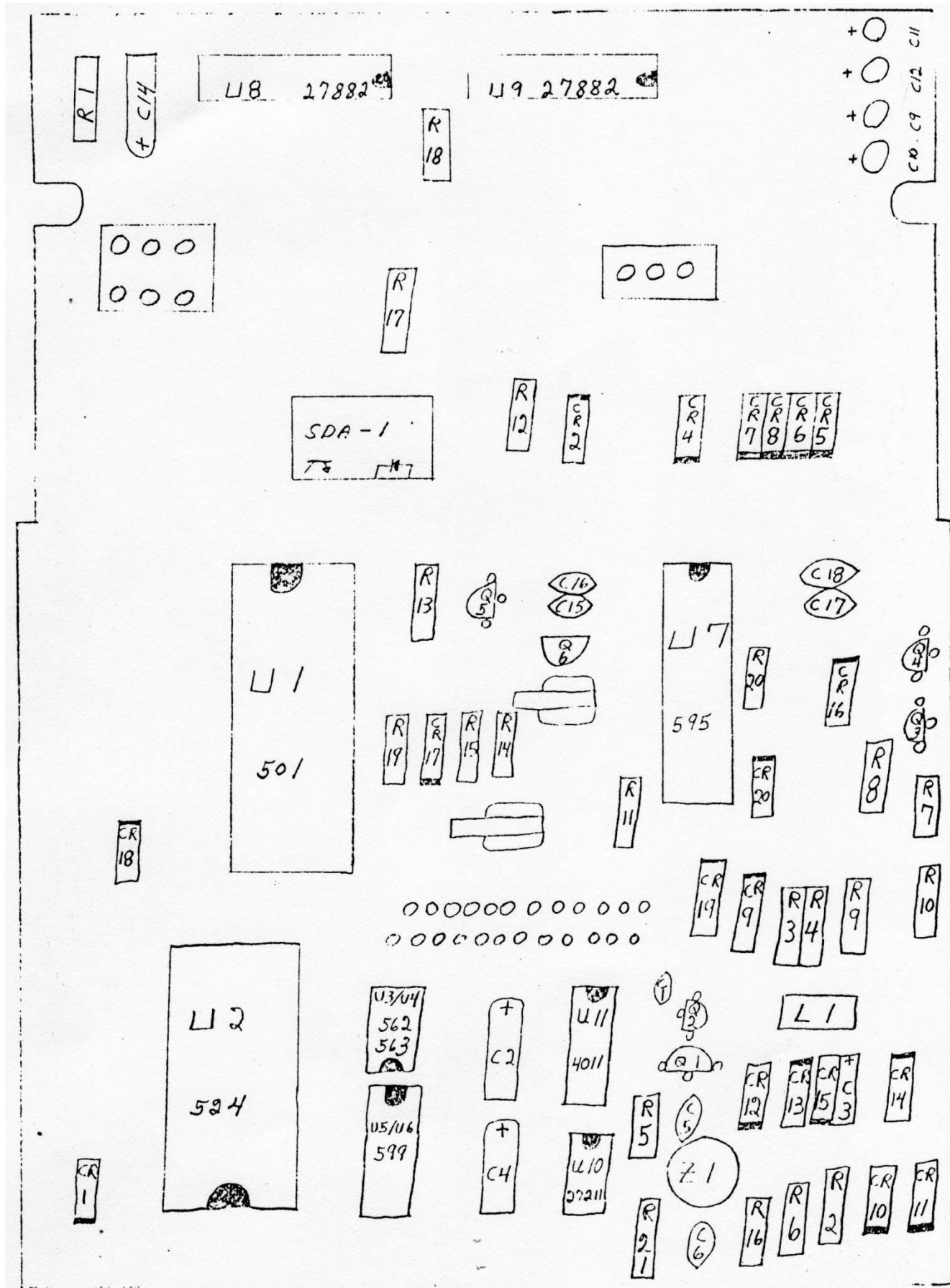

SR-52 Rev. L - COMPONENT LAYOUT

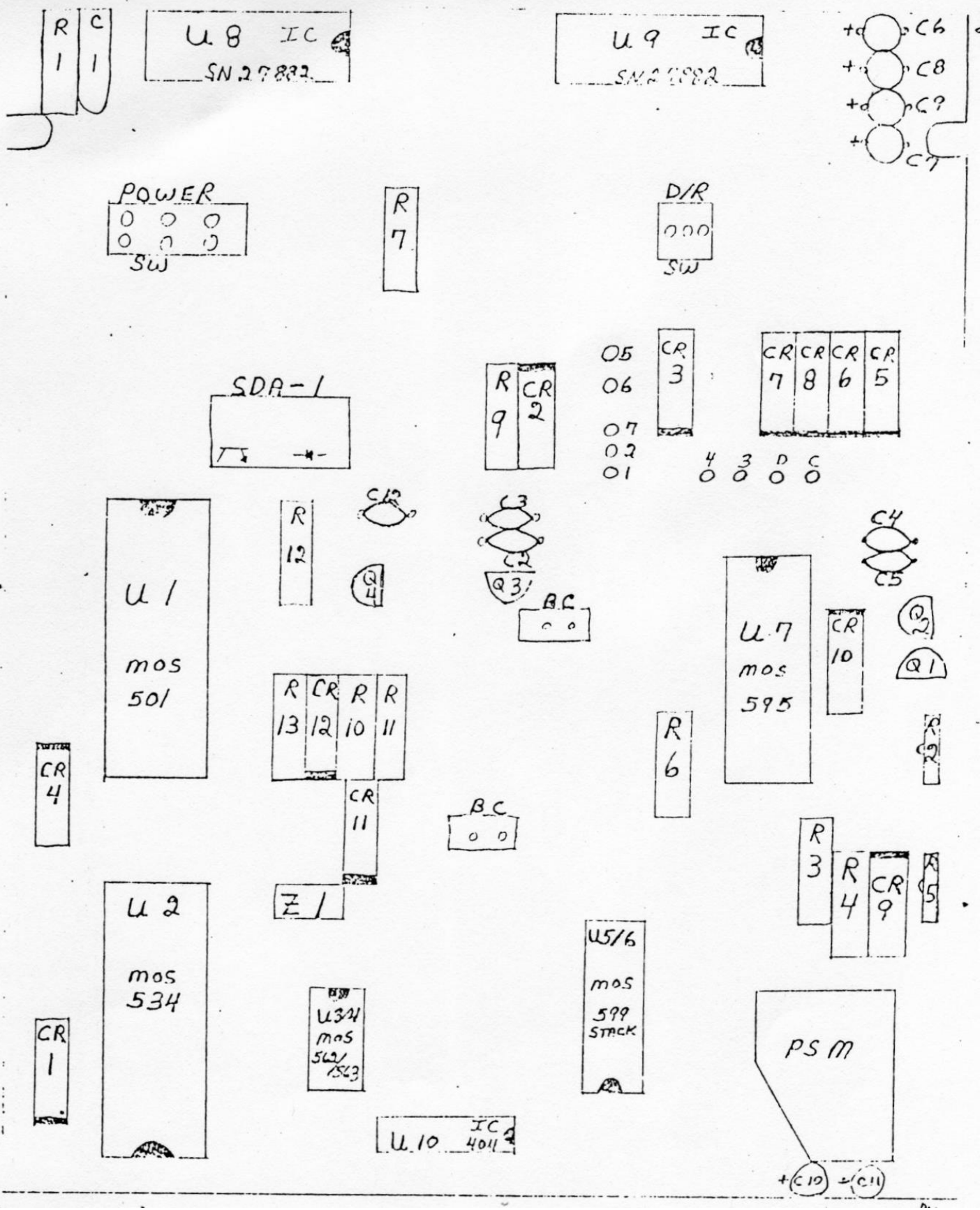

SR-52A COMPONENT LAYOUT

BILL OF MATERIAL LISTING										10/18/76				
SD.DB107.LUB							PAGE 1			Y330				
LOWEST RUN AFFECTED: ___														
PROJ	PARENT PART NUMBER	MC	REV LTR	PART DESCRIPTION	PART TYPE	CYCLE TIME	ORD POL	PLAN OVG %	KIT DEL	WORK MADE	ORD ON	WOMO BLOCK	IDENT	DIST CODE
5000	1220448-8900			SR-52	A	1.0		0.0	390	4100	186	WARRAN TY	H	LUB
		*****						*****	*****					*****
QTY	PER	ITM S	PART NUMBER MC	DESCRIPTION	UM	P	CREDIT	WOMO	EQV TI PT NO		DEL	OPER	EXT	
	.200	1	1220448-5200	TOP CASE ASSY	EA	A	01-5000						\$	
	.010	2	1500773-0037	RES 150 OHM	EA	P	02-5000						\$	
	.050	3	1500502-0026	DIODE 1N757A	EA	P	02-5000						\$	
	.010	4	1500701-0003	CAP 47UF	EA	P	02-5000						\$	
	.010	5	1220439-0001	BATTERY CONTACT	EA	P	02-5000						\$	
	.100	6	1500924-0001	MOS TMC501E	EA	P	02-5000						\$	
	.020	7	1500927-0001	IC TMC0524 MOS	EA	P	02-5000						\$	
	.075	8	1500926-0001	MOS TMC0562C	EA	P	02-5000						\$	
	.075	9	1500925-0001	MOS TMC0563B	EA	P	02-5000						\$	
	.100	10	1500897-0002	MOS TMC0595C	EA	P	02-5000						\$	
	.100	11	1500896-0001	MOS TMC0599D	EA	P	02-5000						\$	
	.020	12	1210013-0012	IC, SN27882	EA	P	02-5000						\$	
	.030	13	1220483-0001	@ IC SN97211	EA	P	02-5000						\$	
	.030	14	1500874-0001	IC 4011A	EA	P	02-5000						\$	
	.050	15	1500993-0001	XSTR 2N3906	EA	P	02-5000						\$	
	.020	16	1501062-0001	XISTOR SKA1872	EA	P	02-5000						\$	
	.020	17	1500501-0001	XSTR, TIS92	EA	P	02-5000						\$	

BILL OF MATERIAL LISTING										10/18/76				
SD.DB107.LUB							PAGE 2			Y330				
LOWEST RUN AFFECTED: ___														
PROJ	PARENT PART NUMBER	MC	REV LTR	PART DESCRIPTION	PART TYPE	CYCLE TIME	ORD POL	PLAN OVG %	KIT DEL	WORK MADE	ORD ON	WOMO BLOCK	IDENT	DIST CODE
5000	1220448-8900			SR-52	A	1.0		0.0	390	4100	186	WARRAN TY	H	LUB
		*****						*****	*****					*****
QTY	PER	ITM S	PART NUMBER MC	DESCRIPTION	UM	P	CREDIT	WOMO	EQV TI PT NO		DEL	OPER	EXT	
	.150	18	1500968-0001	IDCTR TAP	EA	P	02-5000						\$	
	.050	19	1500965-0001	RESONATOR	EA	P	02-5000						\$	
	.250	20	1501060-0017	PCT 2.5MEG	EA	P	02-5000						\$	
	.075	21	1501060-0003	POT 2.5K	EA	P	02-5000						\$	
	.020	22	1501085-0001	XISTOR SKA3109	EA	P	02-5000						\$	
	.075	23	1501088-0001	XISTOR A5T4062	EA	P	02-5000						\$	
	.050	26	1500869-0022	VLED DISPLAY	EA	P	02-5000						\$	
	.075	27	1220433-0001	ASSY KYBC SR52	EA	P	02-5000						\$	
	.020	28	1501080-0001	SWITCH	EA	P	02-5000						\$	
	.075	29	1500947-0001	SWITCH DPST	EA	P	02-5000						\$	
	.100	30	1500982-0001	ASSY SRCE-SENSR	EA	P	02-5000						\$	
	.015	31	1500789-0002	RECEPTACLE	EA	P	02-5000						\$	
	.100	34	1500502-0015	1N746A DIODE	EA	P	02-5000						\$	
	.100	37	1500773-0045	RES 180 OHM	EA	P	02-5000						\$	
	.100	38	1500773-0042	RES 7.5K	EA	P	02-5000						\$	
	.100	39	1500502-0020	IN751A 4000,410	EA	P	02-5000						\$	
	.250	40	1500600-0017	RES 4.7OHM 1 2K	EA	P	02-5000						\$	

BILL OF MATERIAL LISTING											10/18/76					
SD.DB107.LUB								PAGE 3		Y330						
LOWEST RUN AFFECTED: __																
PROJ	PARENT PART NUMBER	MC	REV LTR	PART DESCRIPTION	PART TYPE	CYCLE TIME	ORD POL	PLAN OVG %	KIT DEL	WORK MADE	ORD ON	WOMO BLOCK	IDENT	DIST CODE		
5000	1220448-8900			SR-52	A	1.0		0.0	390	4100	186	WARRAN TY	H	LUB		
	*****							*****	*****					*****		
QTY	PER	ITM S	PART NUMBER MC	DESCRIPTION	UM	P	CREDIT	WOMO	EQV TI PT NO		DEL	OPER	EXT			
	.150	41	1220811-0003	HD MTG ASY	EA	P	02-5000						\$1			
	.025	42	1500773-0125	RES 1M	EA	P	02-5000						\$			
	.050	43	1220442-0001	DECAL INSTR	EA	P	02-5000						\$			
	.025	44	1500789-0002	RECEPTACLE	EA	P	02-5000						\$			
	.003	45	1010782-0001	ADHESIVE	EA	P	10-0109						\$			
	.050	46	1220474-0001	DR MOT/GEAR	EA	P	02-5000						\$			
	.050	47	1020010-0001		EA	P	02-5000						\$			
41 LINES											END OF REPORT		< - - SUB-ITEM NOTES - - >		TOTAL	\$4

BILL OF MATERIAL LISTING										10/18/76				
SD.DB107.LUB							PAGE 2			Y330				
LOWEST RUN AFFECTED: ___														
PROJ	PARENT PART NUMBER	MC	REV LTR	PART DESCRIPTION	PART TYPE	CYCLE TIME	ORD POL	PLAN OVG %	KIT DEL	WORK MADE	ORD ON	WOMO BLOCK	IDENT	DIST CODE
5000	1220449-8900			SR52A	A	.5		0.0	393	4100	110	WARRAN TY	H	LUB
		*****						*****	*****					*****
QTY	PER	ITM S	PART NUMBER MC	DESCRIPTION	UM	P	CREDIT	WOMO	EQV TI PT NO		DEL	OPER	EXT	
	.200	18	1013813-0002	MODULE PS	EA	P	02-5000							\$
	.050	19	1500969-0001	RESONATOR	EA	P	02-5000							\$
	.025	20	1500701-0048	CAP, 22 UF	EA	P	02-5000							\$
	.025	21	1500701-0003	CAP, 47UF	EA	P	02-5000							\$
	.025	22	1500545-0007	CAP .005UF	EA	P	02-5000							\$
	.005	23	1020282-0001	PRINTER CONTACT	EA	P	02-5000							\$
	.075	24	1501060-0003	POT 2.5K	EA	P	02-5000							\$
	.200	25	1501060-0017	POT 2.5MEG	EA	P	02-5000							\$
	.150	27	1500501-0001	XSTR, TIS92	EA	P	02-5000							\$
	.025	28	1500628-0053	CAP 47UF 6V	EA	P	02-5000							\$
	.100	29	1220473-1000	SR52 UPR HSC AS	EA	P	02-5000							\$
	.025	30	1220462-0001	RLB PRESS SR52	EA	P	02-5000							\$
	.250	31	1220465-0002	CARD SPRING NEW	EA	P	02-5000							\$
	.075	32	1220466-0001	CONT MOT SWTCH	EA	P	02-5000							\$
	.010	33	1010478-0023	SCR .11240	EA	P	10-0109							\$
		33A		SUB:1010478-22	EA	P								\$
	.150	34	1500980-5999	WIRE WHT 2	FT	P	10-0109							\$

BILL OF MATERIAL LISTING										10/18/76				
SD.DB107.LUB							PAGE 3			Y330				
LOWEST RUN AFFECTED: ___														
PROJ	PARENT PART NUMBER	MC	REV LTR	PART DESCRIPTION	PART TYPE	CYCLE TIME	ORD POL	PLAN OVG %	KIT DEL	WORK MADE	ORD ON	WOMO BLOCK	IDENT	DIST CODE
5000	1220449-8900			SR52A	A	.5		0.0	393	4100	110	WARRAN TY	H	LUB
		*****						*****	*****					*****
QTY	PER	ITM S	PART NUMBER MC	DESCRIPTION	UM	P	CREDIT	WOMO	EQV TI PT NO		DEL	OPER	EXT	
	.050	35	1220815-0001	PAD RESILI	EA	P	10-0109						\$0.0	
	.250	36	1220811-0003	HD MTG ASY	EA	P	02-5000						\$2.7	
	.250	37	1220460-0001	SR52A LWRHSG	EA	P	02-5000						\$0.0	
	.100	38	1220810-0001	DR RLR SR52	EA	P	02-5000						\$0.0	
	.100	39	1220474-0001	DR MOT/GEAR	EA	P	02-5000						\$0.6	
	.010	40	1010782-0001	ADHESIVE	EA	P	10-0109						\$0.0	
	.200	41	1500516-0006	INSERT SR52	EA	P	10-0109						\$0.0	
	.050	42	1013805-0001	PRESSUR PAD	EA	P	02-5000						\$0.0	
	.050	45	1501042-1409	SCREW	EA	P	10-0109						\$0.0	
	.150	46	1500982-0002	SRCE-SESR ASY	EA	P	02-5000						\$0.3	
	.200	47	1501078-0002	VLED	EA	P	02-5000						\$0.7	
	.025	48	1501080-0001	SWITCH	EA	P	02-5000						\$0.0	
	.050	49	1500947-0001	SWITCH DPST	EA	P	02-5000						\$0.0	
	.200	50	1010727-0007	LEAD FR SR-50 A	EA	P	02-5000						\$0.0	
	.010	51	1013265-0001	INSULATOR	EA	P	10-0109						\$0.0	
	.200	52	1020249-0001	LEAD FRAME	EA	P	02-5000						\$0.0	
	.250	53	1220449-4100	TOP CASE ASY 52A	EA	P	02-5000						\$0.2	

BILL OF MATERIAL LISTING											10/18/76					
SD.DB107.LUB								PAGE 4		Y330						
LOWEST RUN AFFECTED: __																
PROJ	PARENT PART NUMBER	MC	REV LTR	PART DESCRIPTION	PART TYPE	CYCLE TIME	ORD POL	PLAN OVG %	KIT DEL	WORK MADE	ORD ON	WOMO BLOCK	IDENT	DIST CODE		
5000	1220449-8900			SR52A	A	.5		0.0	393	4100	110	WARRAN TY	H	LUB		
	*****							*****	*****					*****		
QTY	PER	ITM S	PART NUMBER MC	DESCRIPTION	UM	P	CREDIT	WOMO	EQV TI PT NO		DEL	OPER	EXT			
	.020	54	1220437-0001	KEYBOARD SUPT	EA	P	02-5000						\$			
	.001	55	1020290-0001	WINDOW	EA	P	02-5000	900					\$			
	.050	56	1220436-0001	SR52 BOT CASE	EA	P	02-5000						\$			
	.100	57	1020093-0002	BLACK FEET	EA	P	10-0109						\$			
	.100	58	1220442-0001	DECAL INSTR	EA	P	02-5000						\$			
56 LINES											END OF REPORT		< - - SUB-ITEM NOTES - - >		TOTAL	\$6

8

7

6

5

KEY BOARD 1220433

DISPLAY 1500869

D

C

B

A

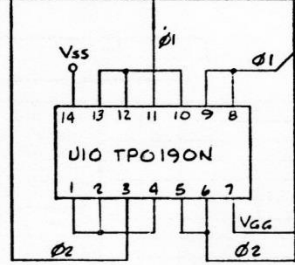
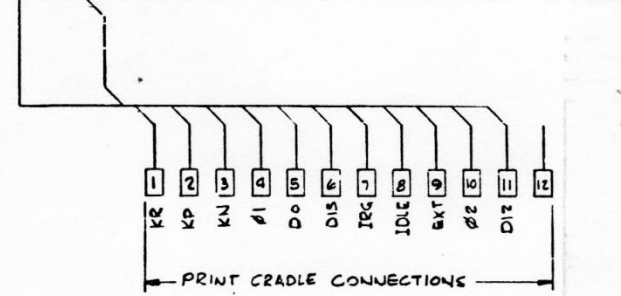
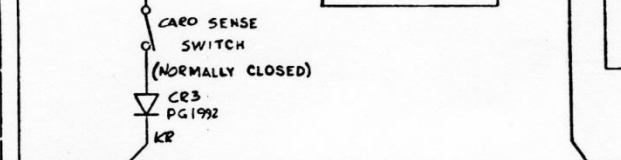
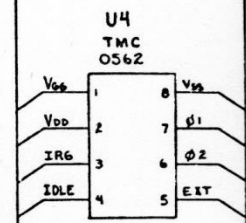
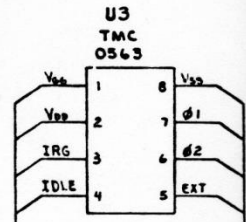
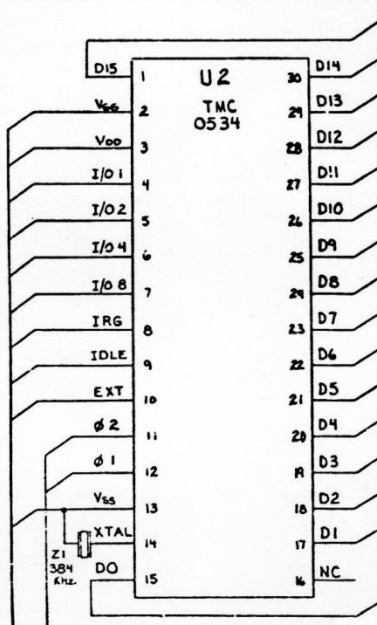
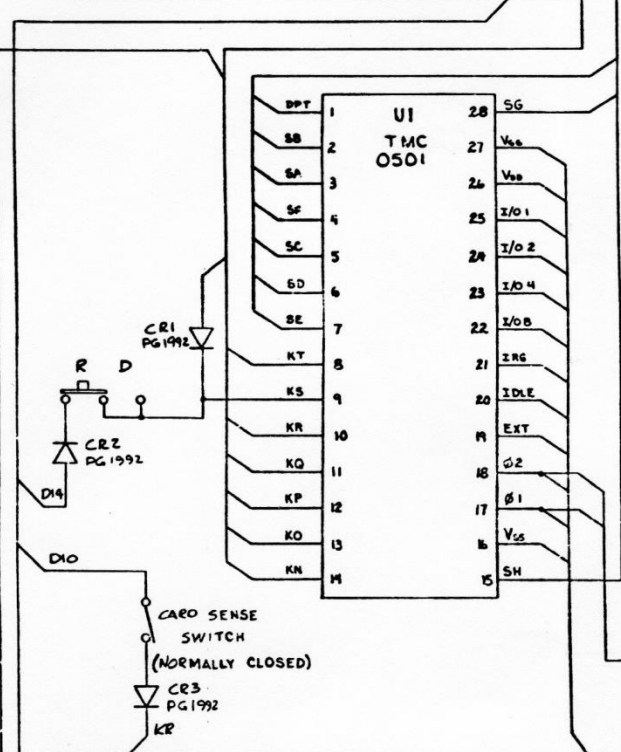
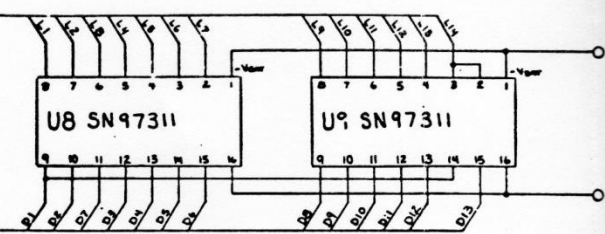
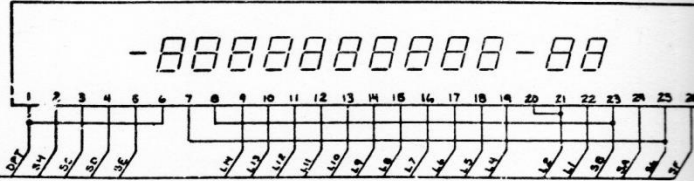
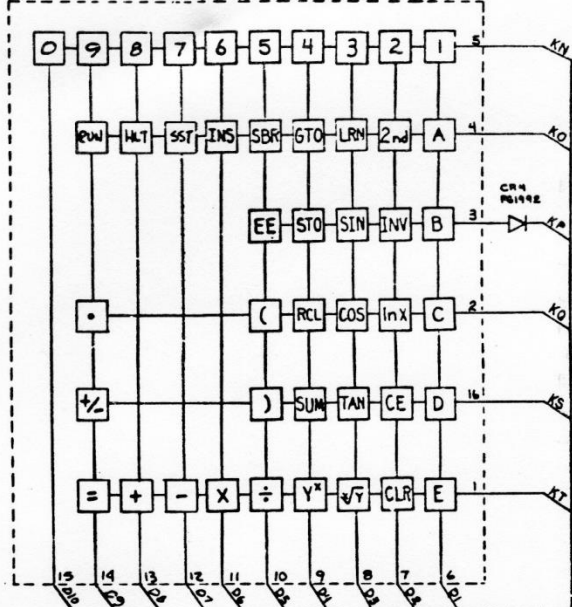

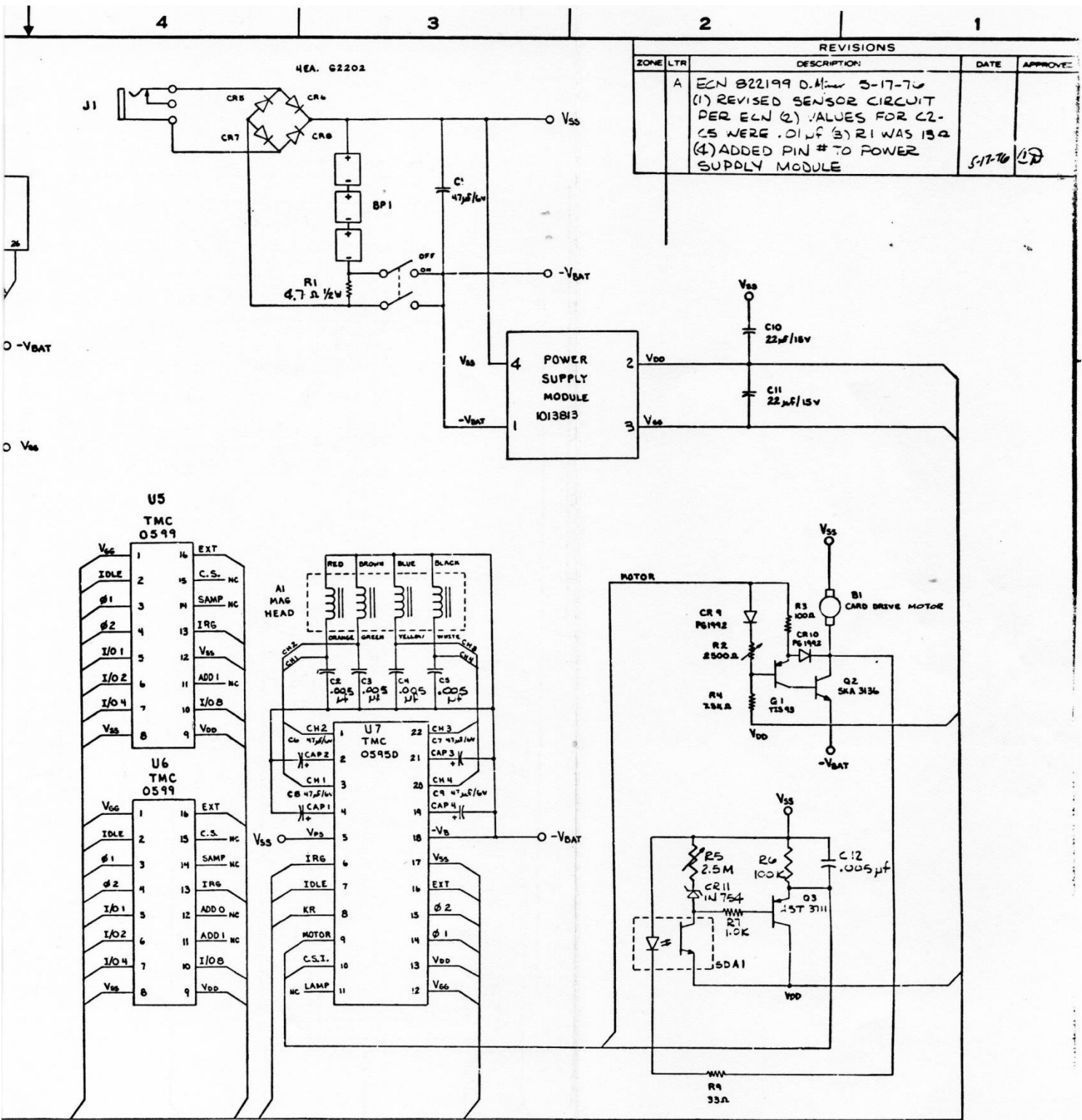

REVISIONS				
ZONE	LTR	DESCRIPTION	DATE	APPROVE
A		ECN 822199 D. Minor 5-17-76 (1) REVISED SENSOR CIRCUIT PER ECN (2) VALUES FOR C2-C5 WERE .01UF (3) R1 WAS 15Ω (4) ADDED PIN # TO POWER SUPPLY MODULE	5-17-76	[Signature]

-2	-1	ITEM NO	PART OR IDENTIFYING NUMBER	NOMENCLATURE OR DESCRIPTION	REMARKS

PARTS LIST			DATE	
			3-9-76	
			3-12-76	
UNLESS OTHERWISE SPECIFIED			DESIGNER	
• DIMENSIONS ARE IN INCHES			[Signature]	
• TOLERANCES			DATE	
• ANGLES =			3/12/76	
• 3 PLACE DECIMALS =			APPROVED	
• 2 PLACE DECIMALS =			[Signature]	
• DIMENSIONING IN ACCORDANCE WITH ANSI Y14.5			DESIGN ACTIVITY RELEASE	
MATERIAL:			3/12/76	
1013811	094		SUP DWG	SIZE D
NEXT ASSY	PRODUCT		DRAWING NO	1013814
APPLICATION			SCALE	REV LTR: A
				SHEET 05/1



ELECTRONIC SCHEMATIC DIAGRAM, SR-52A

CLASS CODE: 40

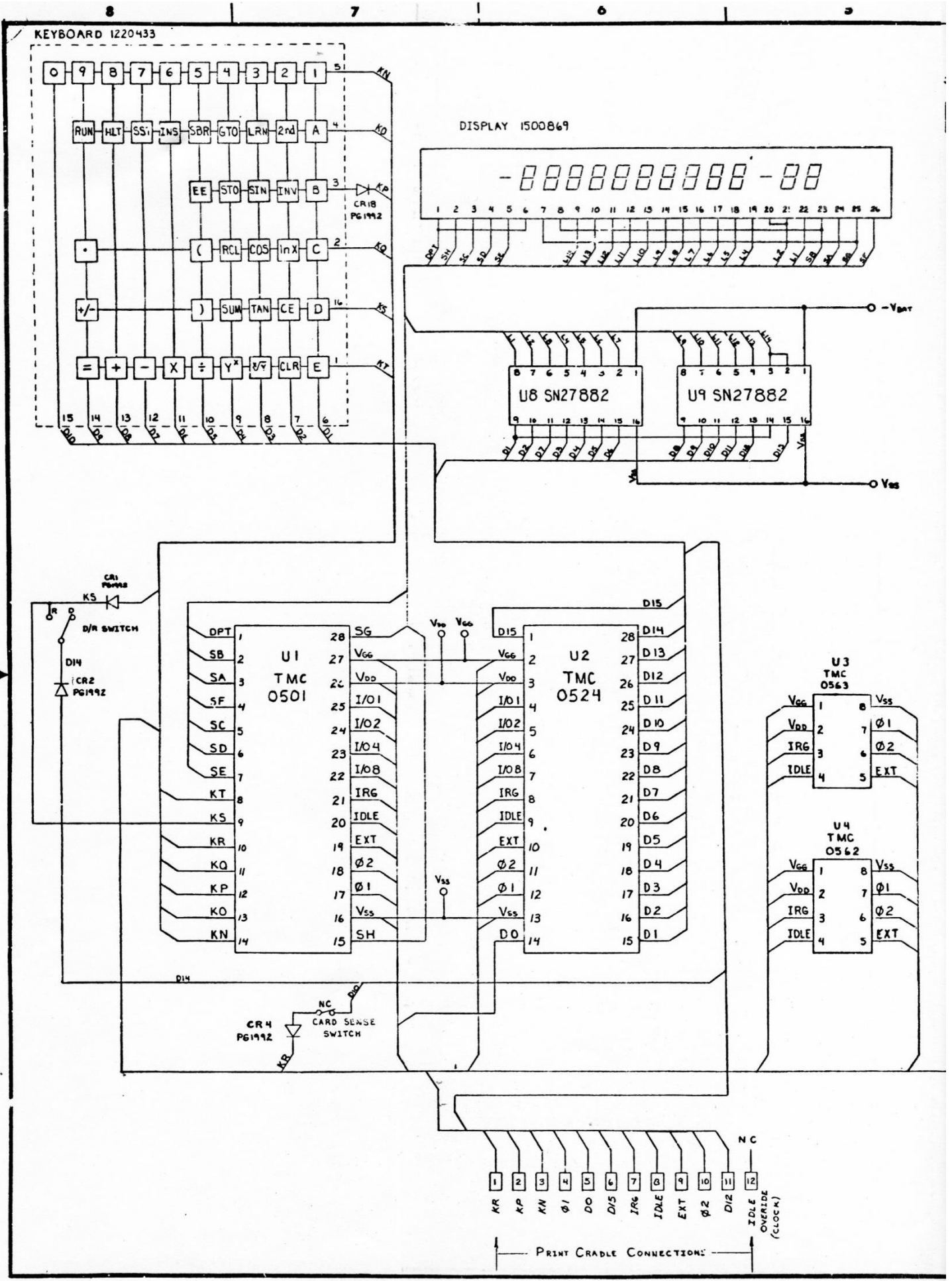

SR-52 REV. D THROUGH L - SCHEMATIC DIAGRAM 1 OF 2

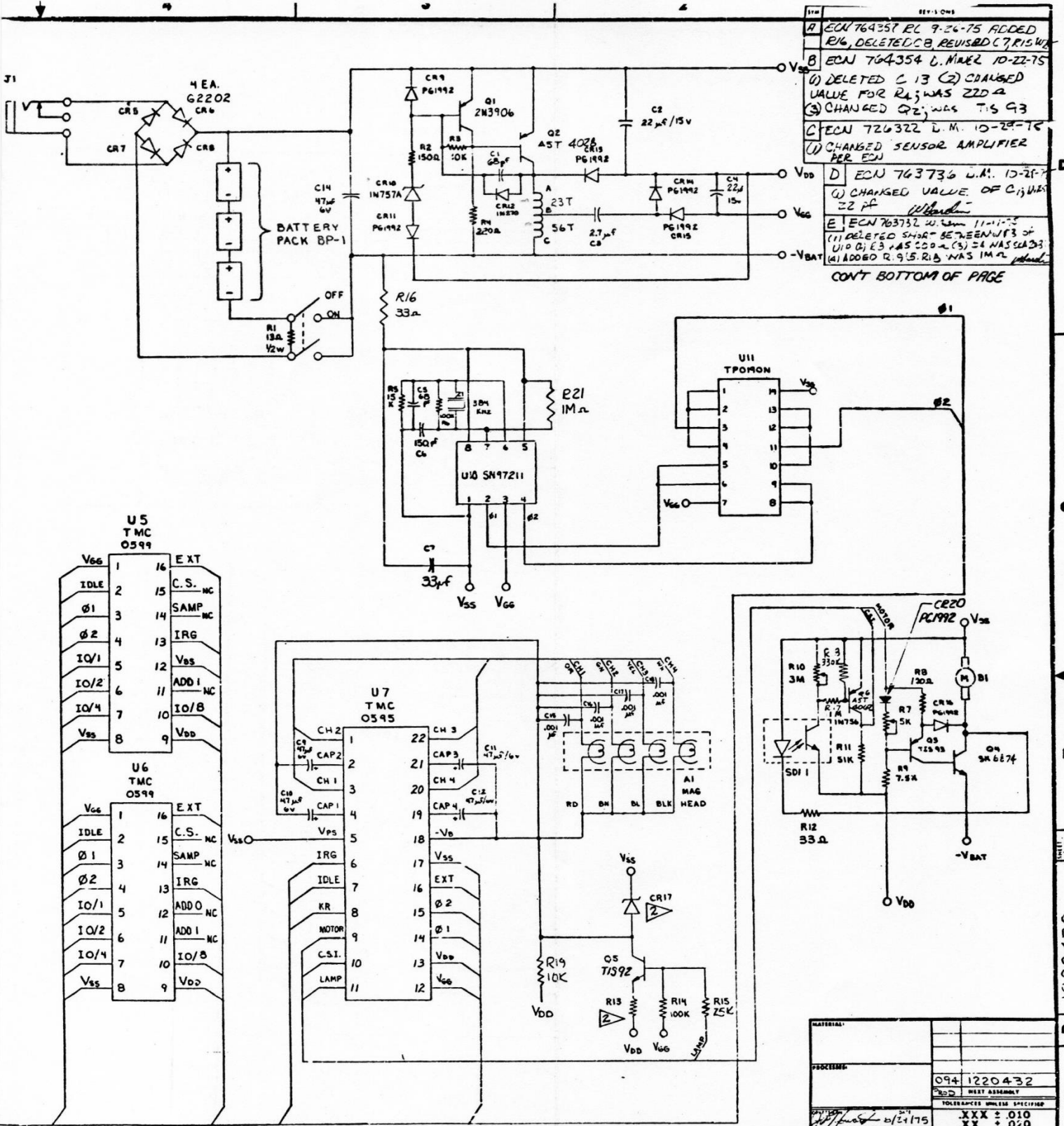

REV: 1.000

A ECN 764357 RL 7-24-75 ADDED R16, DELETED C8, REVISED C7, R15, W

B ECN 764354 L. MINER 10-22-75
 (1) DELETED C 13 (2) CHANGED VALUE FOR R4; WAS 220 Ω
 (3) CHANGED Q2; WAS TIS 93

C ECN 726322 L.M. 10-28-76
 (1) CHANGED SENSOR AMPLIFIER PER EDJ

D ECN 763736 U.M. 10-28-76
 (1) CHANGED VALUE OF C13; WAS 22 pf

E ECN 763732 U.M. 11-11-75
 (1) DELETED SHORT BETWEEN P3 OF U10 Q1; E3 WAS 220 Ω (2) E4 WAS 33 Ω (3) ADDED R 9.5; R13 WAS 1M Ω

CONT BOTTOM OF PAGE

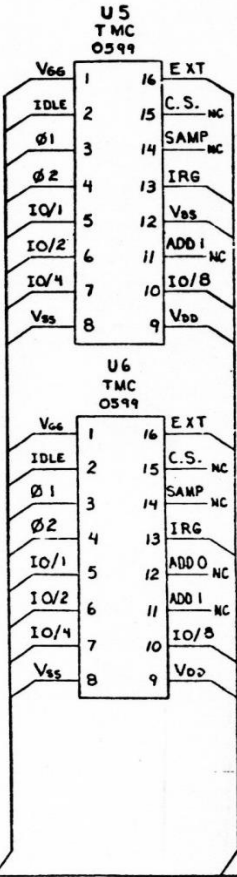

NOTES: UNLESS OTHERWISE SPECIFIED
 1 ALL RESISTORS ARE 1/4 WATT
 2 FOR 595B MOS, CR17 IS INT51A AND R13 IS 240 OHM.
 FOR 595C MOS, CR17 IS INT46A AND R13 IS 330 OHM.

F ECN 795756 RL 1-27-76 ADD CR20, R20, CR19, CHANGED Q5, R4 R21, REMOVED SHORT FROM CR15 TO VSS

G ECN 790842 L. MINER 4-2-76
 (1) DELETED C19 & R20
 (2) DELETED CONNECTING LINES BETWEEN R4 & R4
 (3) CR17 & R13; DELETED INT51A & 240 Ω RESPECTIVELY AND FLAG NOTE 2 CALL-OUT
 (4) ZONE A-4; ADDED NOTE 2

MATERIAL:	
PROJECT:	094 1220432
REV:	REV 001
DATE:	11/17/75
BY:	J. H. H.
CHECKED:	
APPROVED:	
DATE:	
SCALE:	
TOLERANCES UNLESS SPECIFIED	
XXX ± .010	
XX ± .020	
X ± .030	
UNLESS OTHERWISE SPECIFIED	
RESISTORS: 1% UNLESS OTHERWISE SPECIFIED	
CAPACITORS: 5% UNLESS OTHERWISE SPECIFIED	
WELDED: 100% UNLESS OTHERWISE SPECIFIED	
INSULATION: 100% UNLESS OTHERWISE SPECIFIED	
TESTING: 100% UNLESS OTHERWISE SPECIFIED	
TEXAS INSTRUMENTS INCORPORATED	01295
COMPONENTS GROUP	
TITLE:	SCHEMATIC DIAGRAM
	SR-52
SCALE:	D
	1220430

